

Hot Sale Supply Nutrition Rice Production Line Artificial Rice Processing Line

1.Product Description

Human access to food is one of the major sources of nutrition, but the general content of nutrient elements in grains are in varies. As a result of a large number of proteins and trace elements losses during processing, so that greatly reduce nutrients, artificial rice (food Simulation) technology is crowded pressure principle of renewable use in the food breakthrough.

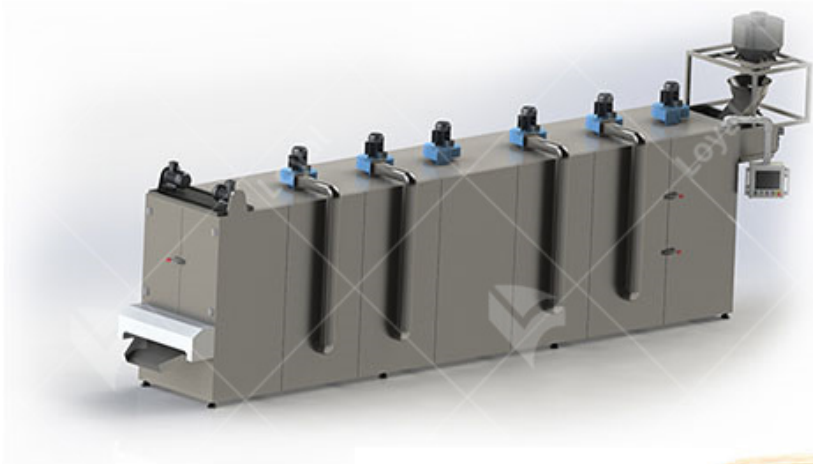

The Fortified Rice Production Line makes it possible to strengthen and solidify the micronutrient in the rice. The most important feature of technology is necessary for the body to add a variety of nutrients to foods to produce a variety of

health food products, food and functional food effects. Products for human consumption easy digestion and absorption, deep by consumers.

2. Specification

Model	Installed power	Power consumption	Throughput	Dimension
LY60	82.6KW	62KW	100-150kg/h	16.5*3*2.6M
LY75-	121KW	91KW	200-250kg/h	18.5*3*2.6M
LY90	126KW	148KW	250-450kg/h	18.8*6.5*2.8M



3. Production Process

Mixer → Screw Conveyor → Single Screw Extruder → Vibrate Cooler → Air Conveyor → Multi-Layer Dryer

Machine	Function
Mixer	Mix the material, make full mix
Screw Conveyor	Conveying the material into the extruder

Screw Extruder	Extruded the material,make it become the puffing rice food.
Vibrating Screen	cooling,Keep rice from sticking
Air Conveyor	Conveying the product
Dryer	Baked the product, removing the surface's water
Cooling Machine	Cooling the product

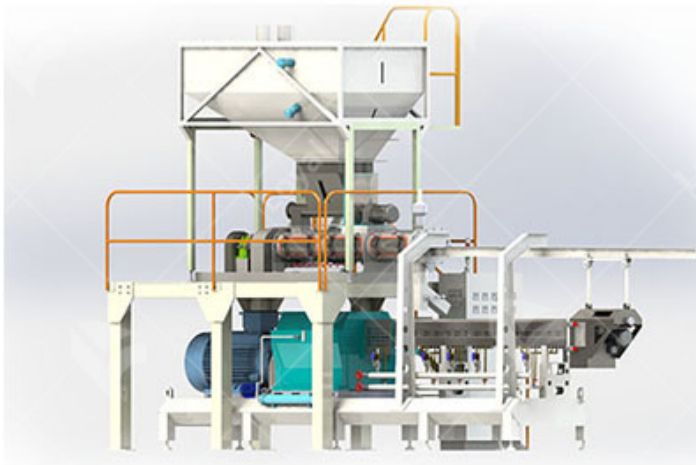

4.Machine Details Display

Our Extruder

<p>1).The feeding machine, main motor and cutting machine adopt advanced converter adjusting speed technology to make the twin screw machine more powerful ,stable and power saving.</p>
<p>2).It is equipped with forced lubricate system to make sure that the transmission part can be used longer.</p>
<p>3).Auto-temperature control system makes the temperature control more direct viewing and the parameter more precise.</p>
<p>4).The screws are made of alloy with nitriding treatment to make sure longer life.</p>

5).The screws can also be self-cleaned.When stopping the machine, there is no need to unload the screw.

6).The twin screw extruder can be widely used in many areas such as corn flakes,breakfast cereals, fried snacks and so on according to different configurations.

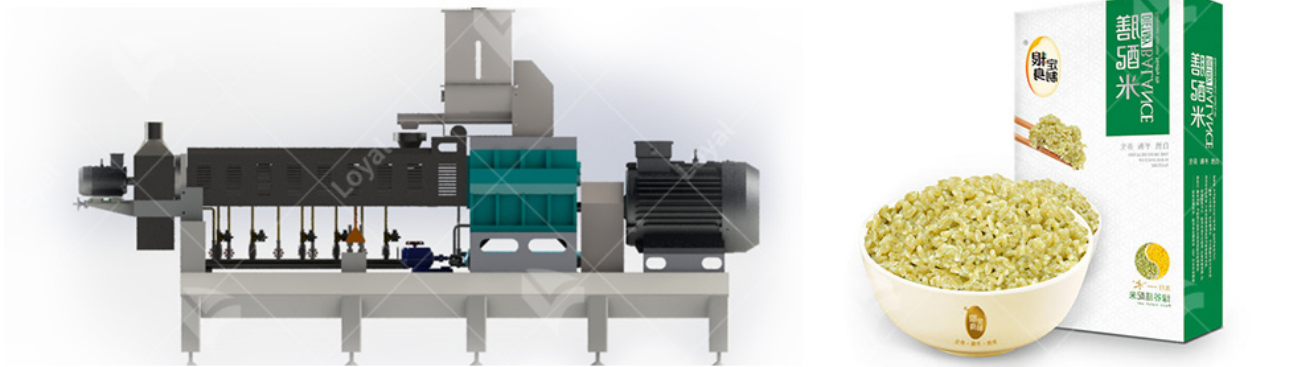

5. Finished Product Display

This corn puffs snacks processing line use corn powder, grain flour and other floury as main material, through mixing, extruding,drying, flavoring and packing, to get flavored corn puffed snacks. It always service as corn puffs mixed with colored agents. This production system can also many kinds of different shapes of corn puffed snacks, such as rings, balls, curls etc

